

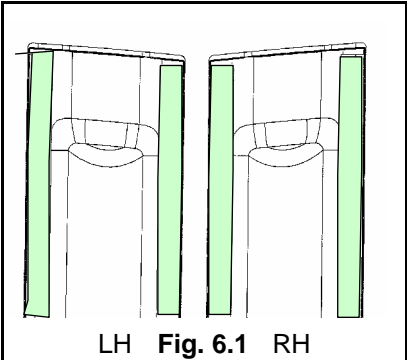

# GENUINE PARTS INSTALLATION INSTRUCTIONS

<b>1. DESCRIPTION:</b>	Body Side Molding																								
<b>2. APPLICATION:</b>	H61B - FRONTIER - KING CAB (2005)																								
<b>3. PART NUMBER:</b>	999G2-xxxxxxx-SK (Body Color Matches)																								
	999G2-BR100S1-SK (Unpainted Service Part - LH)																								
	999G2-BR100S2-SK (Unpainted Service Part - RH)																								
<b>4. KIT CONTENTS:</b>	<div style="display: flex; align-items: flex-start;"> <div style="flex: 1;"> <p>NOTE: LH and RH kits are to be purchased separately.</p> </div> <table border="1" style="border-collapse: collapse; text-align: center;"> <thead> <tr> <th>ITEM No.</th> <th>REQD.</th> <th>NAME</th> </tr> </thead> <tbody> <tr> <td>1</td> <td>1</td> <td>MOLDING - FRT DOOR RH</td> </tr> <tr> <td>2</td> <td>1</td> <td>MOLDING - RR DOOR RH</td> </tr> <tr> <td>3</td> <td>1</td> <td>Instruction <a href="#">Replacement Template</a></td> </tr> <tr> <td> </td> <td> </td> <td> </td> </tr> <tr> <td>1</td> <td>1</td> <td>MOLDING - FRT DOOR LH</td> </tr> <tr> <td>2</td> <td>1</td> <td>MOLDING - RR DOOR LH</td> </tr> <tr> <td>3</td> <td>1</td> <td>Instruction <a href="#">Replacement Template</a></td> </tr> </tbody> </table> </div>	ITEM No.	REQD.	NAME	1	1	MOLDING - FRT DOOR RH	2	1	MOLDING - RR DOOR RH	3	1	Instruction <a href="#">Replacement Template</a>				1	1	MOLDING - FRT DOOR LH	2	1	MOLDING - RR DOOR LH	3	1	Instruction <a href="#">Replacement Template</a>
ITEM No.	REQD.	NAME																							
1	1	MOLDING - FRT DOOR RH																							
2	1	MOLDING - RR DOOR RH																							
3	1	Instruction <a href="#">Replacement Template</a>																							
1	1	MOLDING - FRT DOOR LH																							
2	1	MOLDING - RR DOOR LH																							
3	1	Instruction <a href="#">Replacement Template</a>																							
<b>5. TOOLS REQUIRED:</b>	<ol style="list-style-type: none"> <li>1) clean, lint free wiping cloths</li> <li>2) 50:50 mixture of Isopropyl Alcohol and water</li> <li>3) measuring tape</li> <li>4) masking tape</li> <li>5) flexible rubber roller, 3" - 4" wide, 60-70shore A durometer</li> <li>6) pre-paint preparation cleaner</li> </ol>																								
<b>6. INSTALLATION PRECAUTIONS / NOTES:</b>	<div style="display: flex; align-items: flex-start;"> <div style="flex: 1;">  <p style="text-align: center;">LH <b>Fig. 6.1</b> RH</p> </div> <div style="flex: 2;"> <ol style="list-style-type: none"> <li>1) A complete vehicle set consists of four molding components</li> <li>2) Both the vehicle surface and the body side molding (BSM) must be between 60° and 110°F. If the temperatures are less than this, both the vehicle surfaces and BSM component can be heated with heat lamps or heat guns. Warmer surfaces are desirable for proper "wet-out" of the BSM adhesive tape. Over heating can cause a negative effect on wet-out.</li> <li>3) Make sure to identify each individual component with the correct side of the vehicle. Each component is marked (on the back surface) to indicate which side of the vehicle it is to be applied to: (LH = left hand side, RH = right hand side).</li> </ol> </div> </div>																								

## INSTALLATION INSTRUCTIONS - BODY SIDE MOLDING (BSM)

### 7. SURFACE PREPARATION:

- 1) If the vehicle has been repainted, the paint should be aged at least 24 hours before installing molding components.
- 2) The installation area must be clean. Airborne dust, oils, etc., may contaminate the vehicle surfaces and or the BSM adhesive and reduce the bond of the adhesive tape. The vehicle should be clean and dry. The vehicle application surface should then be washed with an appropriate solvent system. A 50:50 mixture of isopropyl alcohol and water is recommended. This solvent wash must remove all contaminants, leaving no residue. Cleaning must be completed within 10 minutes of the BSM installation. To assure removal of all contaminants, it **is** necessary to first wipe with a pre-paint preparation cleaner and then the 50:50 alcohol and water mixture.

- \* Use clean lint-free wiping cloths or disposable wipes and change them when visually soiled.
- \* Reprocessed rags should not be used as they may contain waxes and or residual contaminants.
- \* Care should be taken that the cleaning cloths do not rub or touch tires or any other surfaces that might contaminate the vehicle application surface.
- \* There should not be any operations after the cleaning procedure that could contaminate the surface.

 3) **After cleaning with the alcohol solution, the vehicle should be thoroughly dried with a clean lint-free cloth or disposable wipe.**

 4) **Do not wash** vehicle or expose to wet environment for 24 hours after applying BSM.

5) **The general tolerance for installing the body side molding parts is +/- 1.0 mm**

## INSTALLATION INSTRUCTIONS - BODY SIDE MOLDING (BSM)

### 8. INSTALLATION PROCEDURE: FRONT DOOR BSM

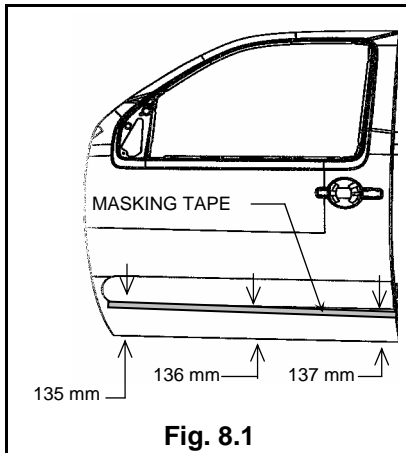

- 1) At the leading edge of the door, locate a small piece of masking tape so that its upper edge is 135 mm **up** from the lower door edge. At the back of the door, locate another small piece of masking tape 137 mm up from the lower door edge. At the Midpoint of the door locate a third small piece of masking tape 136 mm up from the lower door edge.

Stretch a long piece of masking tape across the two small pieces so that the upper edge of the tape creates a horizontal line which will be used to align the molding. Ensure the tape is straight. **(Fig. 8.1, 8.2 & 8.3)**

**Note:** Before removing the adhesive tape liner from the back of each body side molding (BSM) component, identify each part for proper location and fit. Each BSM component is different from the other. Trial fit the components to avoid improper placement. **Ensure the molding end fits within the door depression.**

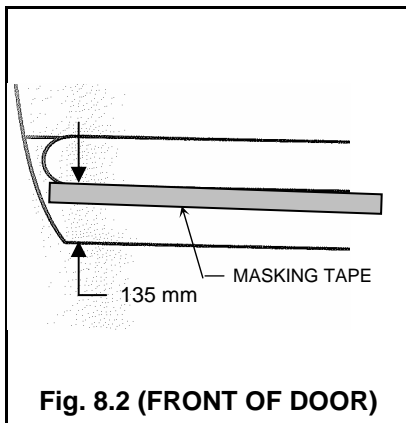

- 2) Starting at the back of the molding carefully peel back approximately half of the tape liner.
- 3) At the back of the door, position the BSM component 4 mm from the back edge of the door right above the masking tape **(leave a 1 mm gap between the molding and the tape)** and lightly tack in place. **(Fig. 8.4)**
- 4) Pull the remainder of the tape liner from the adhesive tape as you place the BSM into position.
- 5) Using a hard rubber roller, apply approximately 30 pounds of pressure (per 1" of tape width) along the top edge of the BSM component, rolling from one end to the other. Repeat rolling the lower part of the BSM. Then roll the curved end portion.
- 6) Repeat process for the opposite side of the vehicle if necessary.

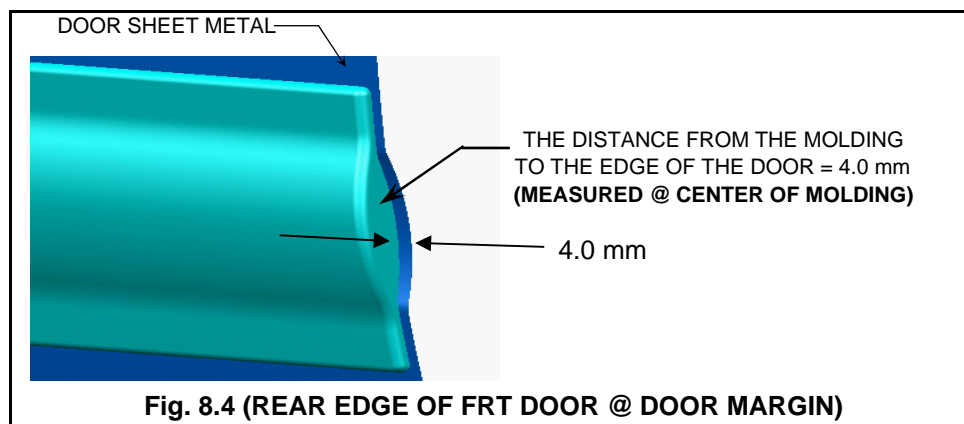
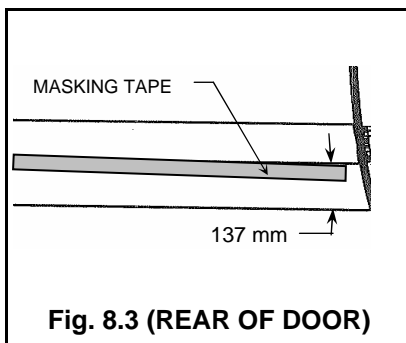

## 9. INSTALLATION PROCEDURE: REAR DOOR BSM

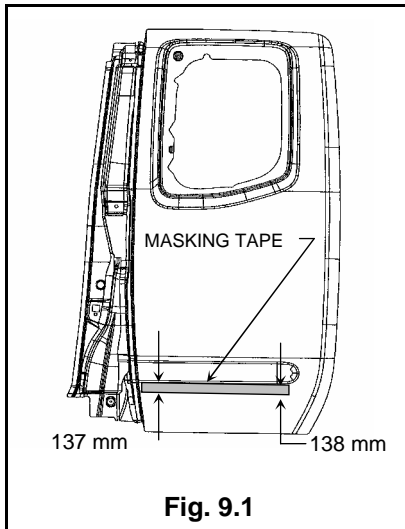

- 1) At the leading edge of the door, locate a small piece of masking tape so that its upper edge is 137 mm **up** from the lower door edge. At the back of the door, locate another small piece of masking tape 138 mm up from the lower door edge.

Stretch a long piece of masking tape across the two small pieces so that the upper edge of the tape creates a horizontal line which will be used to align the molding. Ensure the tape is straight. **(Fig. 9.1, 9.2 & 9.3)**

**Note:** Before removing the adhesive tape liner from the back of each body side molding (BSM) component, identify each part for proper location and fit. Each BSM component is different from the other. Trial fit the components to avoid improper placement. **Ensure the molding fits within the door depression.**

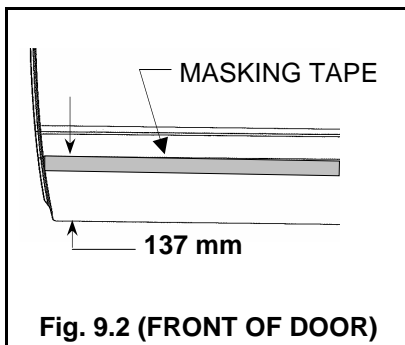

- 2) Starting at the back of the molding (square end) carefully peel back approximately half of the tape liner.
- 3) At the front of the door, position the BSM component 7.5 mm from the front edge of the door right above the masking tape **(leave a 1 mm gap between the molding and tape line)** and lightly tack in place. **(Fig. 9.4)**

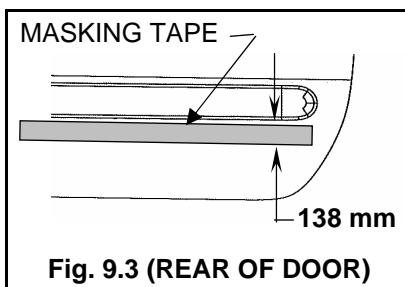

- 4) Pull the remainder of the tape liner from the adhesive tape as you place the BSM into position.
- 5) Using a hard rubber roller, apply approximately 30 pounds of pressure (per 1" of tape width) along the top edge of the BSM component, rolling from one end to the other. Repeat rolling the lower part of the BSM. Then roll the curved end portion.
- 6) Repeat process for the opposite side of the vehicle if necessary.

